

# FIRE EXTINGUISHER MAINTENANCE AND RECHARGE SERVICE MANUAL

## MODEL 250

### 2.5 kg Dry Chemical Powder Fire Extinguisher

#### \*\*\* RECHARGE EXTINGUISHERS IMMEDIATELY AFTER USE \*\*\*

All fire extinguishers should be installed and maintained in accordance with the relevant standards (AS 2444 and AS 1851) and the requirements of all authorities that have jurisdiction in relation to fire extinguishers.

When maintenance is indicated, it should be performed by trained persons using proper equipment. Fire extinguishers are pressure vessels and must be treated with respect and handled with care. They are mechanical devices and require periodic maintenance to be sure that they are ready to operate properly and safely.

Extinguishers should be serviced only with original and genuine spare parts – the use of substitute parts constitutes the void of any warranty covering the equipment.

#### TROUBLE SHOOTING GUIDE

Warning : Determine the source of a leak before the extinguisher is depressurized. The extinguisher must be completely depressurized before any attempt is made to devalve it to correct any leakage problem. To depressurize hold the extinguisher in an inverted position, hold discharge hose and squeeze the discharge lever, be careful a small amount of agent will be discharged. Thoroughly clean all valve parts after depressurizing and valve removal.

<b>Problem</b>	<b>Corrective Action</b>
Leak at Collar O-Ring	Remove valve assembly, clean wing nut thoroughly and install new collar O-Ring. Lubricate O-Ring with Visilox V-728.
Leak through Valve	Install new valve stem assembly. Check valve seat for scratches or foreign matter.
Leak around Gauge threads	Remove Gauge and reinstall using Teflon tape on Gauge threads.
Defective Gauge	Remove defective Gauge and install new Gauge using Teflon tape on the Gauge threads.
Leak in Cylinder	Discard and Replace cylinder

## PARTS LIST AND SCHEMATIC DIAGRAM

### Model 250 2.5 Kg ABE Dry Chemical Powder Extinguisher

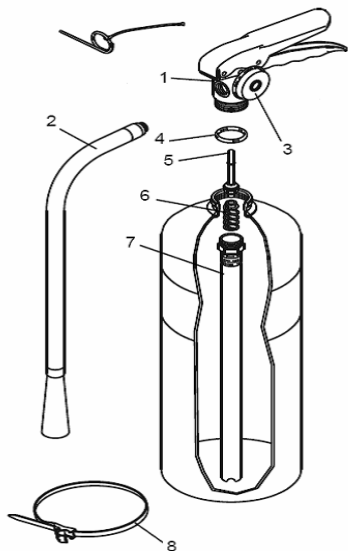

Parts List		
Item	Description	Part No.
1	Valve Assembly	L-2510
2	Hose and Nozzle Assembly	L-2520
3	Gauge	L-2530
4	Collar O-Ring	L-2540
5	Valve Stem Assembly	L-2550
6	Spring	
7	Downtube	
8	Strap & Clip Assembly	L-2580
	Wall Bracket	L-2590
	Label	L-2599
	Ring Pin	L-4000
	ABE Powder	L-5025

## INSPECTING THE EXTINGUISHER

This extinguisher should be inspected at regular intervals (Monthly or more often if circumstances dictate) to insure that it is ready for use. Inspection is a quick check that an extinguisher is available and will operate. Inspection is completed by seeing that the extinguisher is located in its designated place and has not been actuated or tampered with, and that there is no obvious physical damage or condition to prevent operation.

## MAINTENANCE PROCEEDURE

Fire Extinguishers need to be maintained in accordance with the relevant standards AS 1851. Maintenance is a thorough check of the extinguisher. It includes a thorough physical examination and any necessary repair or replacement.

1. Clean Extinguisher to remove dirt, grease or any foreign material. Check to make sure that the instruction Label is securely fastened and legible. Inspect the cylinder for corrosion, abrasion, dents or weld damage. If damage is found to cylinder hydrostatic testing of the cylinder should be carried out to determine if it can continue to be in service or if replacement is necessary. Note: when cleaning avoid the use of solvents around the face of the pressure gauge. They could seriously damage the plastic gauge face.
2. Inspect the extinguisher for damaged, missing or substitute parts. Only genuine parts are approved for use.
3. Weigh extinguisher and compare with weight printed on the label. Recharge extinguisher if weight does not agree with the weight on the label.
4. Check the date of manufacture on the extinguisher. Extinguisher must be hydrostatically tested every 5 years to the test pressure indicated on the label.
5. Visually inspect the pressure gauge :
  - a. If bent, damaged or improper gauge, depressurize and replace.
  - b. If pressure is low, check for leaks.
  - c. If over pressurized (overcharged), reduce to correct pressure and check for leaks.
6. Remove hose and nozzle assembly and visually inspect inside valve body. Chemical in the valve body may indicate that the extinguisher has been partially discharged and should therefore be recharged. Inspect hose and nozzle for blockage or damage – replace as necessary. Blow air through nozzle or discharge hole to ensure passage is clear of foreign material.
7. Inspect the valve assembly for corrosion or damage. Replace valve assembly or component parts as necessary. If valve removal is necessary, complete all steps in the Recharging Procedure.
8. Install Hose and nozzle assembly.
9. Install ring pin and new tamper seal and record service data on the extinguisher inspection tag.
10. Replace the extinguisher in the proper location. Make sure extinguisher fits the bracket properly – install new bracket if necessary.

## RECHARGE PROCEDURE

Recharging is the replacement of the extinguishing agent and also includes the expellant.

- Warning :**
- A. Before attempting to recharge be sure this extinguisher is completely depressurized.
  - B. Use a regulated pressure source.
  - C. Check and calibrate regulator gauge at frequent intervals, the regulator gauge should be used to determine when the intended charging pressure has been reached, do not use the extinguisher gauge for this purpose.
  - D. Never leave an extinguisher connected to a regulator of a high pressure source for an extended period of time. A defective regulator could cause the cylinder to rupture due to excessive pressure.

1. Complete the Maintenance Service Procedure Steps 1 to 8.
2. Empty extinguisher of all remaining pressure and extinguishing agent.
3. Remove valve assembly and disassemble by removing downtube, spring and valve stem assembly. Remove any collar O-Ring from the valve from the cylinder.
4. Thoroughly clean all parts. Blow the valve out with air or nitrogen. Inspect the collar O-Ring, valve stem, and spring – replace as necessary. Lubricate the collar O-Ring, and small O-Ring on the valve stem assembly with Visolox V-728. Do not lubricate the valve stem seal. Inspect the downtube. If it is cracked, deformed or does not have a threaded brass spring retainer – replace. Inspect downtube O-Ring – replace if necessary.
5. Inspect the interior following the visual inspection standard.
6. Fill extinguisher with 2.5 kg of ABE powder (Part No L-5025).
7. Install valve assembly to the cylinder. Caution – hand tighten valve – over tightening will damage the valve.
8. Pressurize to 1000kPa with nitrogen.
9. Check for leaks using leak detection fluid or a solution of soapy water.
10. Install hose and nozzle assembly.
11. Install ring pin and new tamper seal. Record recharge date and attach new recharge tag.
12. Weigh assembled extinguisher and confirm that the total weight agrees with the weight indicated on the extinguisher label. Install the extinguisher in its proper location. Check the bracket for damage – replace if necessary.

